

PILOT PLANT SERVICE FOR CHEMICAL INTERESTERIFICATION OF OILS AND FATS

NOOR LIDA HABI MAT DIAN; MISKANDAR MAT SAHRI; RAFIDAH ABD HAMID and MOHAMAD RODDY RAMLI



MPOB INFORMATION SERIES • ISSN 1511-7871 • JUNE 2015

MPOB TS No. 150

In their native form, most edible oils have limited application in food products. They are often modified, chemically and/or physically, to alter their textural properties and enhance their functionality in food applications. Interesterification (IE) is a powerful tool for modification of the textural properties of oils and fats, and is currently the perfect alternative to hydrogenation. IE involves redistribution and interchange of fatty acids (FA) within and between the triacylglycerol (TAG) molecules of the oils and fats by means of an appropriate catalyst (Augustin and Versteeg, 2006). The result is a significant change in the physicochemical properties of the oils and fats, such as melting and crystallisation behaviour, viscosity and functionality (Lee *et al.*, 2012; Noor Lida *et al.*, 2007; 2006; 2002). No change to the FA composition occurs, and no formation of either *trans* or geometrical isomers of FA. Nowadays, the production of many textural foods such as margarines, shortenings and confectionery fats, rely heavily on the success of the IE process to produce tailor-made fats, which are free of *trans* FA. This is because IE can offer a real synergy between the textural properties and melting properties of the two constituting fats. IE fats are typically used for food applications such as margarines, shortenings and confectionery fats where the plasticity or texture of the fat is of utmost importance to the general appreciation of the product.

Two types of IE process are available, namely chemical and enzymatic IE. Chemical IE is catalysed by chemicals such as metallic sodium and sodium alloy. Chemical IE leads to a random distribution of FA over the TAG molecules. It is carried out at high temperatures of 100°C-120°C (Rosendaal, 1990). Chemical IE reaction occurs very rapidly once started, and equilibrium is reached within minutes. It is a tried-and-true process as it has been around for a long time. Thus, industrial procedures and equipment are

readily available. Chemical IE is currently the most applied technique for the modification process of oils and fats as it is a simple and cost-effective, produces healthy modified oils without destruction of natural minor components (e.g. vitamin E), and does not produce *trans* FA, which is believed to have a negative impact on health (Amir *et al.*, 2012). The drawbacks of chemical IE are the loss of oil due to the formation of soap and methyl esters upon removal of the catalyst by washing with water, and the requirement of a series of prerequisite post-treatment process such as washing, bleaching and deodorisation (Sreenivasan, 1978).

CHEMICAL INTERESTERIFICATION PROCESS

The chemical IE reaction is catalysed by sodium methoxide, and is carried out at a relatively high temperature, *i.e.* at 110°C, under vacuum. The chemically interesterified oil requires a series of post-treatment processes, namely, washing, bleaching and deodorisation. Generally, chemical IE process involves the following steps:

1. Pumping the oil into IE vessel and removing the air to create a vacuum.
2. Heating the oil at 110°C for 1-2 hr to remove moisture.
3. Initiating the IE reaction by addition of sodium methoxide (0.01%-0.02%).
4. Cooling the interesterified oil to 70°C.
5. Washing the interesterified oil with a dilute aqueous citric acid solution (0.4%) 3-4 times to remove soap by-products, then drying under vacuum.
6. Bleaching the interesterified oil to remove residual soaps, trace metals and oxidised bodies.

ISSN 1511-7871



9 771511 787001

Malaysian Palm Oil Board, Ministry of Plantation Industries and Commodities, Malaysia

6 Persiaran Institusi, Bandar Baru Bangi, 43000 Kajang, Selangor, Malaysia.

Tel: 03-8769 4400

Fax: 03-8925 9446

Website: www.mpob.gov.my



7. Deodourising the interesterified oil to remove free fatty acids (FFA) and other volatile impurities to produce refined, bleached and deodorised interesterified oil.

DESCRIPTION OF CHEMICAL INTERESTERIFICATION PILOT PLANT

Chemical Interesterification Pilot Plant at the Malaysian Palm Oil Board (MPOB) (Figure 1) consists

of a high pressure reaction vessel integrated with refining facilities. It is a batch-wise pilot plant with a production capacity of 50 to 100 kg interesterified oil per batch.

CHARACTERISTICS OF CHEMICALLY INTERESTERIFIED OIL

The chemically interesterified oil produced at the MPOB Chemical Interesterification Pilot Plant is of

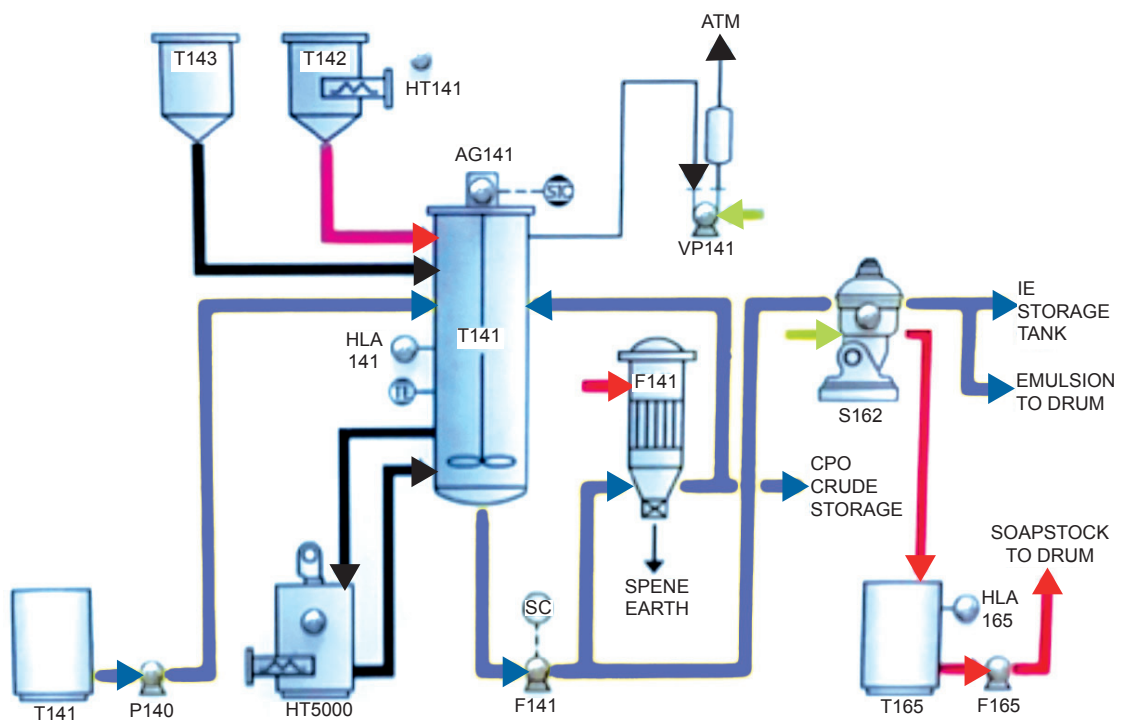

Figure 1. Chemical Interesterification Pilot Plant integrated with refining facilities.

good quality with very low FFA content (< 0.05%), peroxide value (<0.5 meq kg⁻¹) and moisture content (<0.05%). The solid fat content profile of the chemically interesterified oil is very similar to interesterified oil produced using the random enzymatic IE process, as illustrated in Figure 2.

ADVANTAGES OF CHEMICAL INTERESTERIFICATION PILOT PLANT

- Uses simple, clean and safe process. IE of oils and fats is achieved in less than 30 min.
- Batch-wise pilot plant with a flexible production capacity ranging from 50-100 kg of interesterified oil per batch.
- Integrated with refining facilities for post-treatments (bleaching and deodorisation) of the interesterified oil.

SERVICE OFFERED

MPOB offers a service of chemical IE of oils and fats using the Chemical Interesterification Pilot Plant. The service is offered at a minimal fee, depending on the production capacity and post-treatments involved. The service fee includes IE and post-treatment processes, sample analyses before and after IE [FFA content, solid fat content, Differential Scanning Calorimetry (DSC) melting and crystallisation properties and slip melting point], and consultation.

REFERENCES

AMIR, R M; SHABBIR, M A; KHAN, M R and HUSSAIN, S (2012). Interesterification of fats and oils – a review. *Pak. J. Food Sci.*, 22(3): 143-153.

AUGUSTIN, M A and VERSTEEG, C (2006). Milk fat: physical, chemical and enzymatic modification. *Advanced Dairy Chemistry* (Fox, P F and McSweeney, P L H eds.). Volume 2 Lipids. 3rd ed. Springer Science+Business Media, New York.

LEE, Y; TANG, T and LAI, O M (2012). Health benefits, enzymatic production, and application of medium- and long-chain triacylglycerol (MLCT) in food industries: a review. *J. Food Sci.*, 77: 137-144.

NOOR LIDA, H M D; SUNDRAM, K and NOR AINI, I (2007). Effects of chemical interesterification on the triacylglycerol and solid fat content profile of palm stearin, sunflower oil and palm kernel olein blends. *European Journal of Lipid Science and Technology*, 109:147-156.

NOOR LIDA, H M D; SUNDRAM, K and NOR AINI, I (2006). DSC study on the melting properties of palm oil, sunflower oil and palm kernel olein blends before and after chemical interesterification. *J. Amer. Oil Chem. Soc.*, 83(8): 739-745.

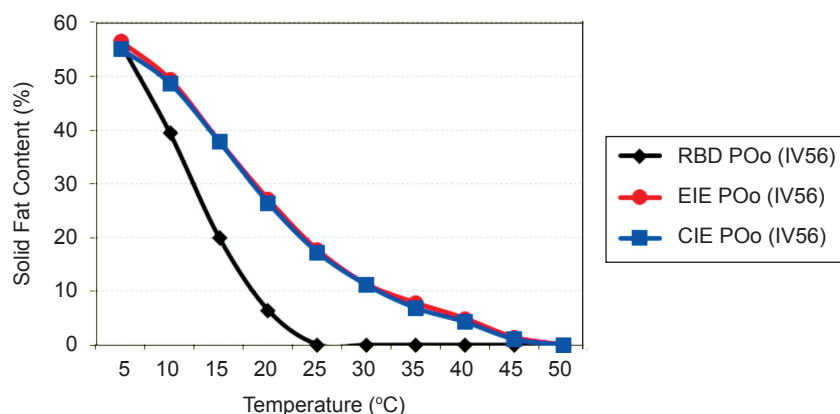

Figure 2. Solid fat content profile of palm olein with iodine value of 56 before interesterification (RBD POo IV56), after chemical interesterification (CIE POo IV56) catalysed by sodium methoxide using Chemical Interesterification Pilot Plant, and after enzymatic interesterification (EIE POo IV56) catalysed by non-specific lipase.

NOOR LIDA, H M D; SUNDRAM, K; SIEW, W L; AMINAH, A and MAMOT, S (2002). Triacylglycerol composition and solid fat content of palm oil, sunflower oil and palm kernel olein blends before and after chemical interesterification. *J. Amer. Oil Chem. Soc.*, 79(11):1137-1144.

ROSENDAAL, A (1990). Interesterification of oils and fats. *World Conference Proceedings, Edible Fats and Oils Processing: Basic Principles and Modern Practices*. American Oils Chemists' Society. United States of America. p.152-157.

SREENIVASAN, B (1978). Interesterification of fats. *J. Amer. Oil Chem. Soc.*, 55: 796-805.

For more information, kindly contact:

Director-General
MPOB
6 Persiaran Institusi, Bandar Baru Bangi,
43000 Kajang, Selangor, Malaysia.
Tel: 03-8769 4400
Fax: 03-8925 9446
www.mpob.gov.my